



ISR – SENSOR LIFT

for Medium-to-Large Gimbals



FEATURES

- Perfect Visibility (360°)
- Lightweight Construction
- Triple Redundancy Safety System
- Fixed and Rotary Wing Compatible
- Optional Pressure Dome
- Non-ITAR

External Camera Lift on AW109; Internal Camera Lift for 10" gimbal

Sensor Lift Solution for every airborne platform

Airborne Technologies develops moveable lifting devices accommodating gimbals up to 26" diameter, mounted internally or externally.

The design has been constantly improved and results in a mature solution that demonstrated its reliability and durability on different platforms and in the most diverse harsh environments. The lift offers an electromechanical retraction system in a lightweight, self-supporting structure providing maximum strength for FOD, bird strike protection and covert surveillance operations.

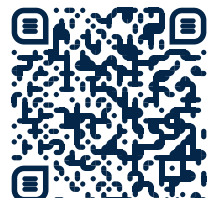

ISR – SENSOR LIFT

for Medium-to-Large Gimbals



Internal Camera Lift

CERTIFIED

for aircraft classes

- ✓ CS-29
- ✓ CS-27
- ✓ CS-25
- ✓ CS-23

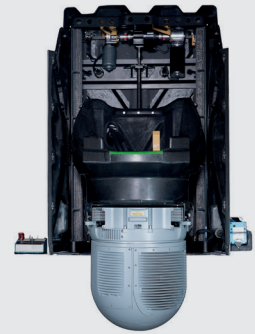

TECHNICAL DATA

(for 20" Gimbal Lift)

- Empty Mass: 40 kg/88,2 lbs
- Min/Max Sensor Diameter: from 10" – 26" / 25 cm – 66 cm
- Max. Sensor Load: 100 kg/220,5 lbs
- Dimensions envelope: h/w/d 1.003 mm/650 mm/712 mm
- Construction: Carbon Fibre (CFRP)
- Status: in production and operational
- Control panel for lift with status indication (extended/retracted/in transition)

Redundancy System
Retraction System powered
by an independent battery pack
and manual retraction.

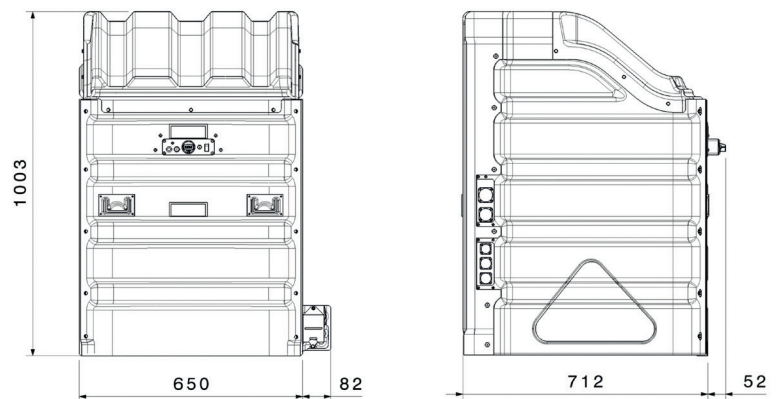

All dimensions in mm



Battery for emergency retraction



Control Panel for camera lift

Airborne Technologies GmbH

Viktor Lang-Strasse 8
2700 Wiener Neustadt, Austria
0043 2622 34718200

sales@airbornetechnologies.at
www.airbornetechnologies.at

Data for other gimbals on request.

Designed for Precision