

Quattro DigiCAM

Designed for Precision

SYSTEM INTEGRATION

Do you need more electrical power for your mission equipment?
Do you need your equipment installed and certified in your aircraft?
Are you considering to procure a new aircraft and/or sensor equipment?

AIRBORNE TECHNOLOGIES is your partner

Design // Integration // Testing EASA Part M/145, Design Organization AP 320

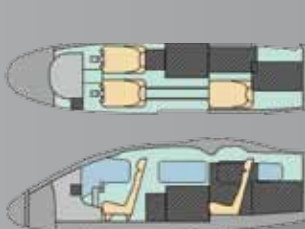

Evaluation

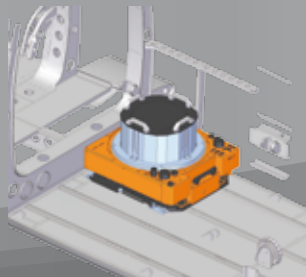

Design



Installation



Flight

WE DO THE JOB!

WE ARE THE LINK BETWEEN
AIRCRAFT- AND SENSOR MANUFACTURER



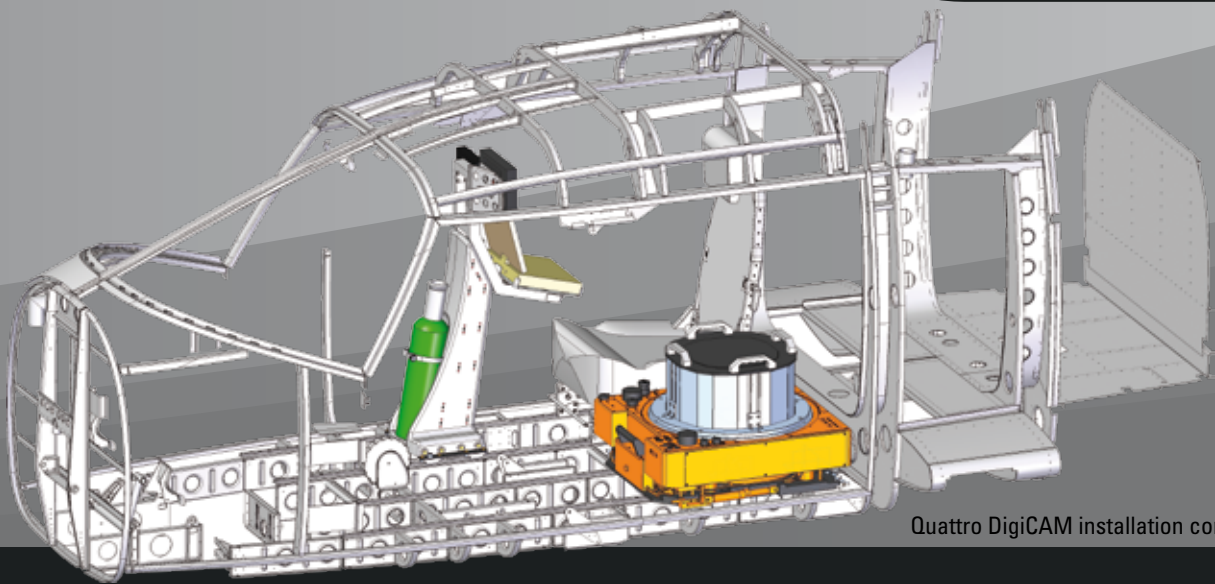

Quattro DigiCAM installation concept

Designed for Precision

Airborne Technologies

is your integration partner for all IGI products:

- CCNS
- AEROcontrol
- DigiCAM
- DigiTHERM
- LiteMapper

Installation in Cessna 182

Installation in Vulcanair P68

Installation in Tecnam MMA



EASA Design Organization AP 320

Airborne Technologies GmbH
Wiener Straße 113/2.11.C
2700 Wr. Neustadt, Austria

info@airbornetechnologies.at
www.airbornetechnologies.at
P+43 2622 34718, F+43 2622 34718 15