



- TYPICAL MISSION FACTS**
- Sensor Payload Up To 650 KG
 - Take Off & Landing Everywhere
 - Up To 10 HRS Turboprop Endurance
 - Min. Mission Speed: 63 KIAS

Airborne Technologies

SYSTEM INTEGRATION

PC-6 Turbo Porter

THE WORKHORSE In The Special Mission Industry

PILATUS PC-6 MULTI MISSION CONFIGURATION

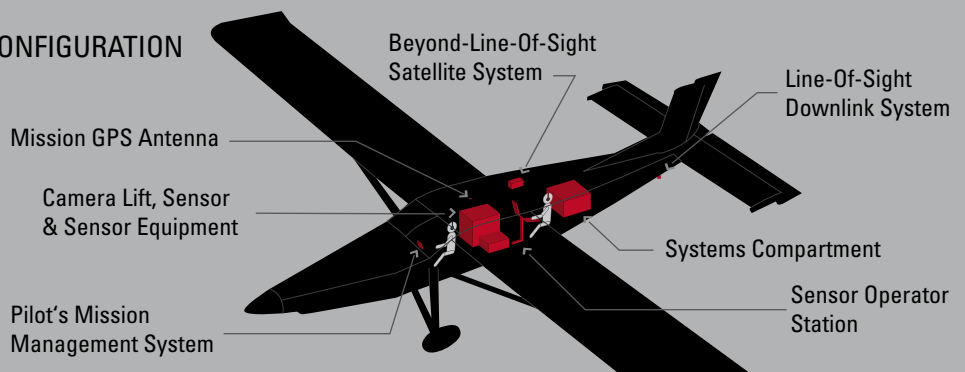

Sensor Operator Station & Camera Lift

PC-6, Landing On Rough Terrain

FLIR Sensor Installation

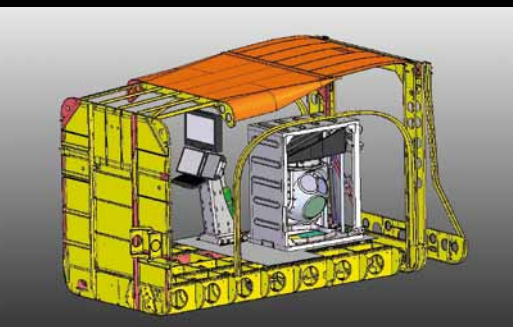

EASA Design Organization AP 320



PILATUS System Integration Partner

Performance data PC-6 Turbo Porter

Performance

Take-off distance over 50 ft (15 m) obstacle (STOL)	1,444 ft	440 m
Landing distance over 50 ft (15 m) obstacle (STOL)	1,033 ft	315 m
Rate of climb (MTOW)	1,010 ft/min	5.13 m/sec
Max. cruise speed	125 KTAS	232 km/h
Max. range at 10,000 ft	500 nm	926 km
- with underwing tanks	870 nm	1611 km
Max. operating altitude	25,000 ft	7620 m
Stall speed		
- flaps up (Vs)	58 KEAS kt	107 km/h
- full flaps set (VSO)	52 KEAS kt	96 km/h

Engine	Pratt and Whitney, Turboprop PT6A-27	
---------------	---	--

Weights

Basic empty weight*	approx 2,756 - 3,086 lb	1,250 - 1,400 kg
Max. take-off weight	6,173 lb	2,800 kg
Max. landing weight	5,863 lb	2,660 kg
Max. payload*	up to approx. 2,646 lb	1,200 kg
Payload with max. fuel*	up to approx. 2,381 lb	1,080 kg

*depending on configuration and fuel

Dimension & Geometry

Wing span	52.07 ft	15.87 m
Wing area	324.54 ft ²	30.15 m ²
Overall length	35.76 ft	0.90 m
Height	10.50 ft	3.20 m
Track	9.84 ft	3.00 m

Fuel	Jet A, Jet A-1, Jet B ASTM-D-/655	
-------------	--------------------------------------	--



Integration of Mission Equipment on carbon fiber platform for easy configuration change

Surveillance

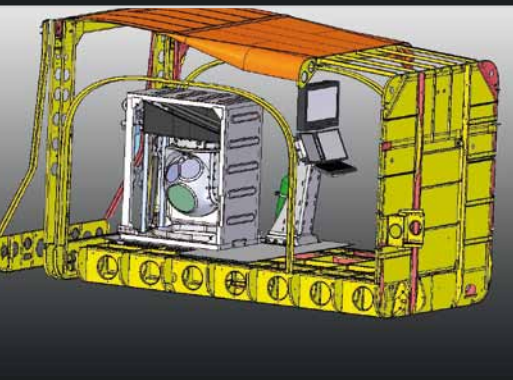

Laser Scanning

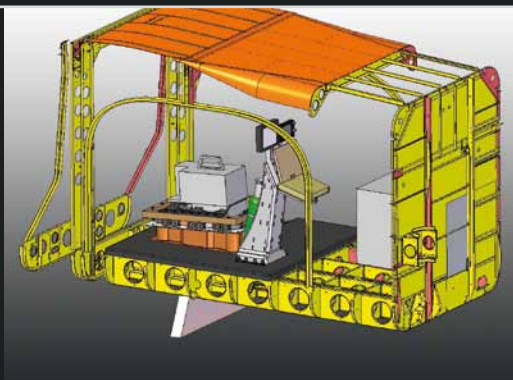

Photogrammetry

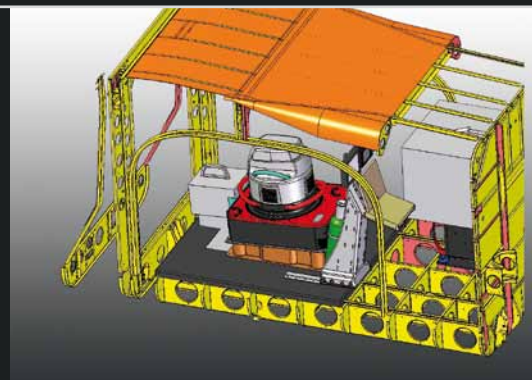

electrically operated hatch doors